

## Built to Order Softwall Cleanrooms

### Creative Solutions

All *Flexible Solutions* Softwall Cleanrooms are self contained and floor supported. *SAM* Fan Filter Units , CRI Cleanroom Light Fixtures, *Cleanguard* Ceiling Panels and curtain walls are included as a complete package.

We build a wide variety of customized *Flexible Solutions* Softwall Cleanrooms. You tell us your requirements and our sales and engineering staff will design a creative solution.

These pages illustrate examples of custom designed softwall cleanrooms for specialized applications.

### General Specifications

**Frame:** Prefabricated white painted steel frame.

**Leg:** At the bottom of each leg is a standard base plate with four (4) mounting holes for securing to the floor.

**Ceiling System:** Painted support structure, perimeter wall angle and aluminum T-Grid. CRI supplies closed cell gasket to be field installed on the load carrying flanges for minimizing leaks.

**Curtain Panels:** All sides are enclosed with standard 40 mil clear vinyl curtain panels with length appropriate to size and classification. Curtain panels are field installed utilizing an aluminum mounting track.

**Strip Door:** Standard access to the clean room is via a 4' strip door consisting of 8" 80 mil clear vinyl strips overlapped 2". The strip door is attached to the cleanroom frame utilizing an aluminum mounting track during on-site assembly.

**Interior Height:** Standard interior height is 8'. Other heights are available.

**Lighting:** Cleanroom LED Light Fixtures are maintenance free, 20 ga. durable steel, with a textured polystyrene diffuser. Features include a 120-277 multi-voltage long life LED system, with a pre-mounted driver for easy installation. 60,000 hrs. LED projected life. Lights are UL listed and DLC QPL certified.

**Ceiling Panels:** Ceiling spaces not occupied by *SAM* Fan Filter Units or light fixtures contain nominal 2' x 4' CRI *Cleanguard* ceiling panels with sealed edges and white vinyl laminated on one side. The panels are heavy enough to continuously compress the gasket on the ceiling T-Grid system.

**Fan Filter Units:** *SAM* 2' x 4' Fan Filter Units manufactured by Clean Rooms International Inc. *SAM* units include a disposable pre-filter and final filter with a minimum efficiency rating of 99.99% on all particles @ .3 microns and larger. See Section 4 for more information on *SAM* units.

**Electrical:** Electrical connections to the building power source are to be completed on site by a qualified electrician at buyer's cost.

**Assembly:** Softwall Cleanrooms are knocked down for shipment. Detailed assembly instructions included with shipment.

**Upgrades:** Easy to upgrade from ISO Class 9 to 6 or Federal Standard 209 Class 100,000 to Class 100.

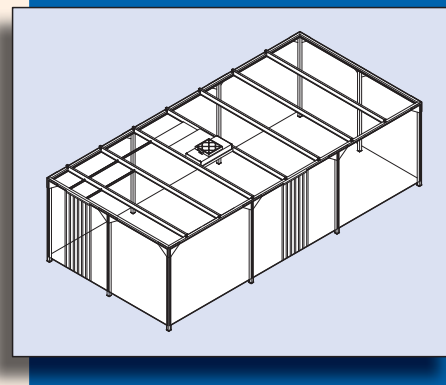
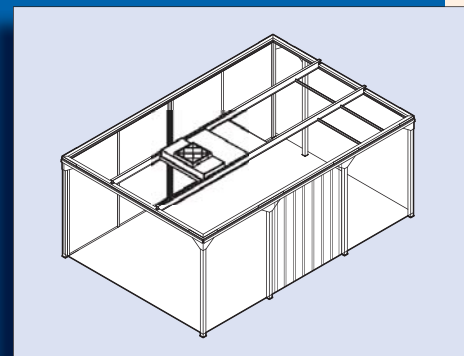
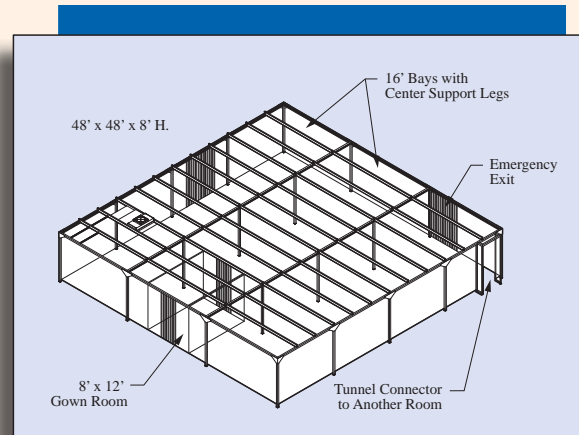

## Built to Order Softwall Cleanrooms

### Upgrade to Higher Class

When a higher class is needed, simply add more SAM Units to achieve a higher class without compromising the structural integrity. (See Figures 1, 2, & 3.)

### Virtually Unlimited Options are Offered

- SAMlink Control System
- Anti-static curtains
- Magnehelic gage control panel
- Variations of interior height
- Perimeter fascia
- Telescoping Legs
- Castors with brake
- Deluxe strip door with alternating frosted strips
- 20, 40, 60 or 80 mil curtains
- Frosted, Yellow/Amber, Smoke, Black Opaque curtains
- SAM units with HEPA filters replaceable from roomside
- Ducted filter modules (Terminal Diffusers)
- SAM Haz Loc Units for hazardous locations
- Seismic Zone Requirements

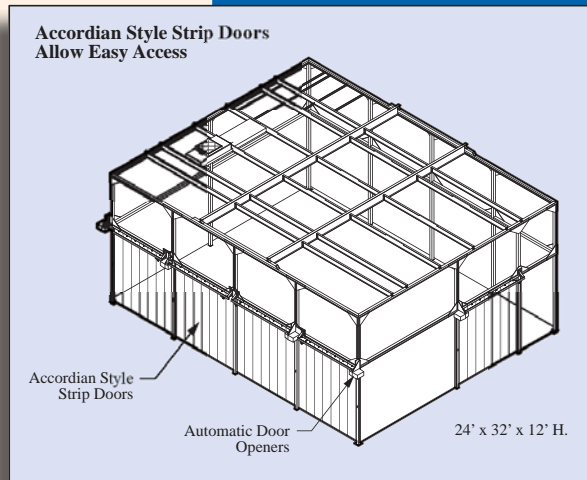
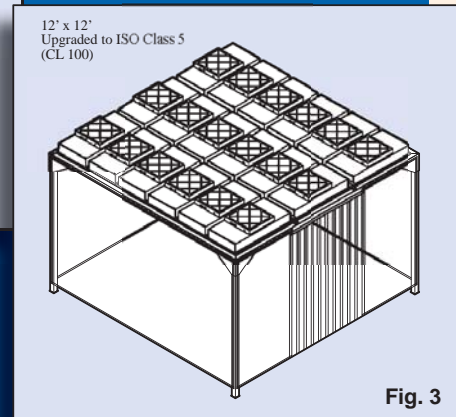
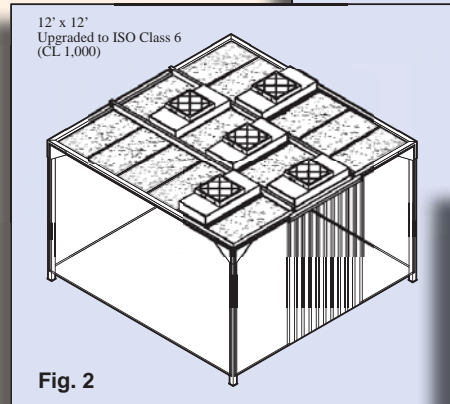
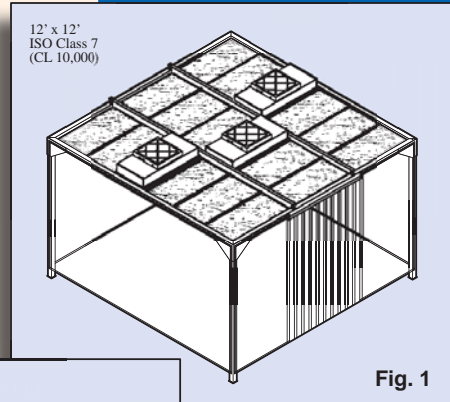

Refer to the following pages or consult with our factory for more information.